

Franke Liquid Soap & Lotion Dispenser

Chrome and SilkSteel

Installation Instructions



Installation

Either use an existing hole or prepare one specially. The hole should be 25mm in diameter. It is recommended that the centre of the hole should be no more than 100mm from the inside edge of the basin or sink. When choosing a location remember to consider any obstructions underneath the surface. See Fig 1. (overleaf).

Pass the connector through the rubber washer and in turn through the hole. Then do up the nut, finger tight, from beneath. Push the bottle over the four lugs at the bottom of the connector, until it clicks into position. See Fig 2. (overleaf). Push the dip into the bottom of the pump.

Fill the bottle (500ml) through the connector and pass the head assembly down into the connector. You can use the dip tube as a measure of how full the bottle is. See Fig 3. (overleaf).

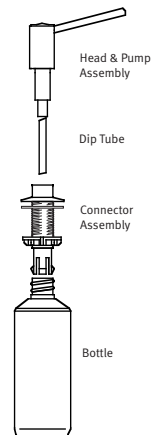

Franke Liquid Soap & Lotion Dispenser

Chrome and SilkSteel

Operation

The pump is worked by a single, full movement downward on the dispenser head. When first used it will be necessary to prime the pump with several movements.

Each movement will dispense 1ml of liquid at 45° to the work surface.

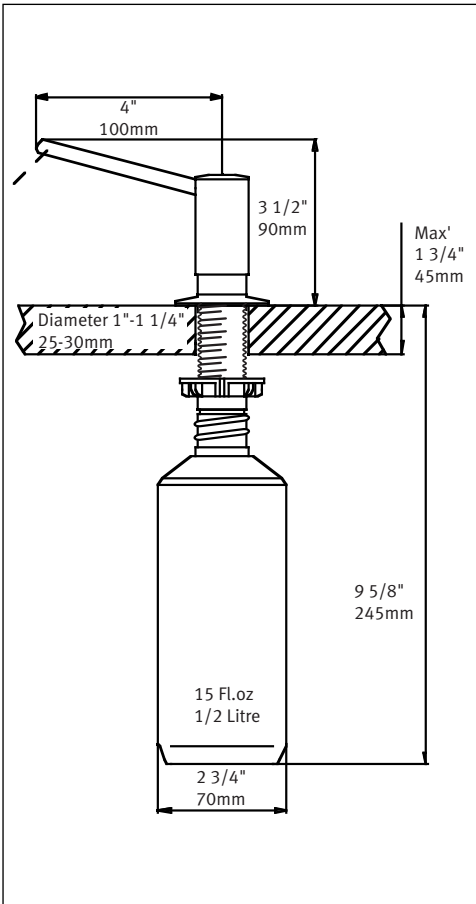

Fig 1

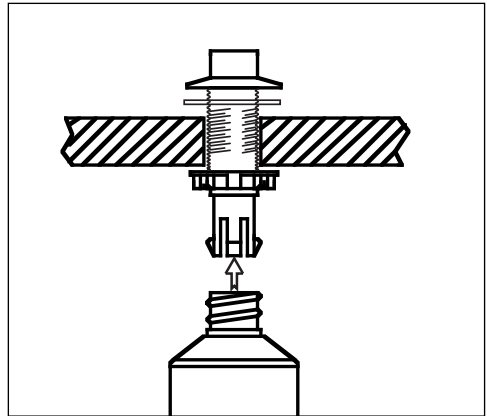

Fig 2

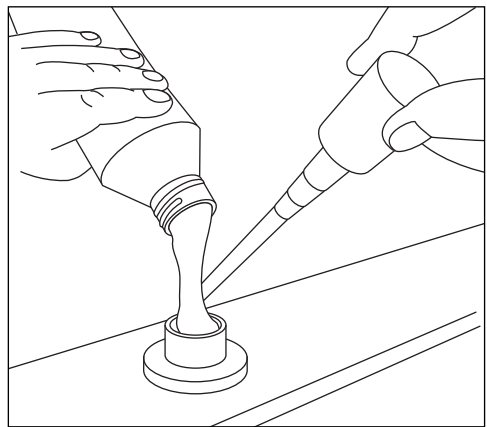

Fig 3

Franke Liquid Soap & Lotion Dispenser

Care and Cleaning

Brassware

It is very important that the product be wiped clean with a soft damp cloth and wiped dry after every use to ensure longevity of the finish.

Under no circumstances should an abrasive cleaner or combination cleaner/polish be used on these products. The abrasive nature of such products will eventually destroy the finish and void the warranty.

In the event of stubborn blemishes on the finish, use a window cleaning product with a soft cloth but this should not be done on an everyday basis.

Stainless Steel

To maintain the pleasing appearance of your stainless steel product you must perform periodic and frequent cleaning. For best results, stainless steel should be cleaned as often as necessary to prevent films or deposits which may eventually cause corrosion – from settling upon the surface. Whenever possible rinse thoroughly with clean water and a soft cloth and blot dry completely. Ordinary deposits of waste and fluids can usually be removed with mild soap and water and a soft cloth.

Never use cleaning products containing abrasive cleaners, ammonia, bleach, acids, or chemicals as these can damage the finish. Allowing salty solutions to evaporate and dry on Stainless Steel may contribute to corrosive conditions and should be avoided as this will destroy the finish and void the warranty.

Troubleshooting

Q. Dispenser not dispensing soap

A. If the dispenser has not been used for some time soap may have congealed in spout or pump. Remove head/pump assembly from connector (see installation instructions). Remove dip tube by pulling from base of pump. Turn head/pump assembly upside down and flush through with clean warm/hot water. When clear, water will run from spout end. If still blocked, soak head/pump assembly in hot water for 10 minutes then repeat flushing procedure.

Q. Spout still blocked

A. If new and not blocked with soap. It could be blocked by manufacturing residue. Remove head/pump assembly from connector (see installation instructions). Push a long fine needle down through the hole in the spout to clear debris. Wash out as described above.

Q. Stiff pump

A. Flush out as described above. If still not working contact your distributor.

Q. Soap leaking

It is likely that the spout is blocked. Flush out as

described above. If this does not cure problem then the pump is probably faulty. Contact your distributor for a replacement.

Q. How to refill

A. Do not try to detach bottle. Remove head/pump assembly from connector (see installation instructions). Refill from top.

Q. Bottle leaking

A. Check if bottle is split. Contact: your distributor for a replacement.

Q. Missing parts

A. Check against installation leaflet to see which parts are missing. Contact your distributor for replacements.

Q. Metal finish flaking off or stained

A. Possibly improper care and cleaning – see care and cleaning recommendations.

Q. Green coloured residue on dispenser

A. Clean off with non-abrasive cleaner or soft cloth – see care and cleaning recommendations.

Failure to comply with these care and cleaning instructions may void any warranty obligations.

Franke UK Limited

West Park, MIOC

Styal Road

Manchester M22 5WB

www.franke.co.uk

Service & Spares:

Central Services 01782 599 258

mail@central-servicesuk.co.uk

www.central-servicesuk.co.uk

South Services 0844 800 3346

sales@south-services.co.uk

www.south-services.co.uk

